

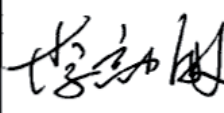

Product Specification

Product Name: VGM128064C2B01

Product Code: M00990

Customer
Approved by Customer
Approved Date:

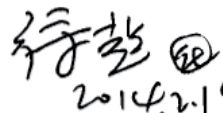
Designed By	Checked By	Approved By	
		R&D	QA
魏燕柳 2/19/14	 2/19/14	 2014.2.19	 2014.2.19

CONTENT

REVISION RECORD	3
1 OVERVIEW	4
2 FEATURES.....	4
3 MECHANICAL DATA	4
4 MECHANICAL DRAWING	5
5 MODULE INTERFACE.....	6
6 FUNCTION BLOCK DIAGRAM	7
6.1 FUNCTION BLOCK DIAGRAM.....	7
6.2 PANEL LAYOUT DIAGRAM	7
7 ABSOLUTE MAXIMUM RATINGS.....	8
8 ELECTRICAL CHARACTERISTICS	8
8.1 DC ELECTRICAL CHARACTERISTICS	8
8.2 ELECTRO-OPTICAL CHARACTERISTICS	9
8.3 AC ELECTRICAL CHARACTERISTICS	10
9 FUNCTIONAL SPECIFICATION AND APPLICATION CIRCUIT	11
9.1 POWER ON AND POWER OFF SEQUENCE.....	11
9.2 APPLICATION CIRCUIT.....	12
9.3 EXTERNAL DC-DC APPLICATION CIRCUIT	14
9.4 DISPLAY CONTROL INSTRUCTION.....	15
9.5 RECOMMENDED SOFTWARE INITIALIZATION	15
10 PACKAGE SPECIFICATION.....	16
11 RELIABILITY	17
11.1 RELIABILITY TEST.....	17
11.2 LIFETIME.....	17
11.3 FAILURE CHECK STANDARD.....	17
12 ILLUSTRATION OF OLED PRODUCT NAME	18
13 OUTGOING QUALITY CONTROL SPECIFICATIONS.....	19
13.1 SAMPLING METHOD	19
13.2 INSPECTION CONDITIONS	19
13.3 QUALITY ASSURANCE ZONES.....	19
13.4 INSPECTION STANDARD.....	20
14 PRECAUTIONS FOR OPERATION AND STORAGE.....	23
14.1 PRECAUTIONS FOR OPERATION	23
14.2 SOLDERING	23
14.3 PRECAUTIONS FOR STORAGE.....	23
14.4 WARRANTY PERIOD	23

1 Overview

VGM128064C2B01 is a monochrome OLED display module with 128×64 dot matrix. The characteristics of this display module are high brightness, self-emission, high contrast ratio, slim/thin outline, wide viewing angle, wide temperature range, and low power consumption.

2 Features

- Display Color: Blue
- Dot Matrix:128×64
- Driver IC: SH1106G
- Interface: 4-Wire SPI.
- Wide range of operating temperature: -40°C to 70°C

3 Mechanical Data

NO.	ITEM	SPECIFICATION	UNIT
1	Dot Matrix	128(W)×64(H)	-
2	Dot Size	0.15(W)×0.155 (H)	mm ²
3	Dot Pitch	0.17(W)×0.175 (H)	mm ²
4	Aperture Rate	78	%
5	Active Area	21.74(W)×11.18 (H)	mm ²
6	Panel Size	26.7(W)×19.26(H)×1.05 (T)	mm ³
7	Module Size	26.7(W)×31.26(H)×1.28 (T)	mm ³
8	Diagonal A/A Size	0.96	inch
9	Module Weight	1.28±10%	gram

4 Mechanical Drawing

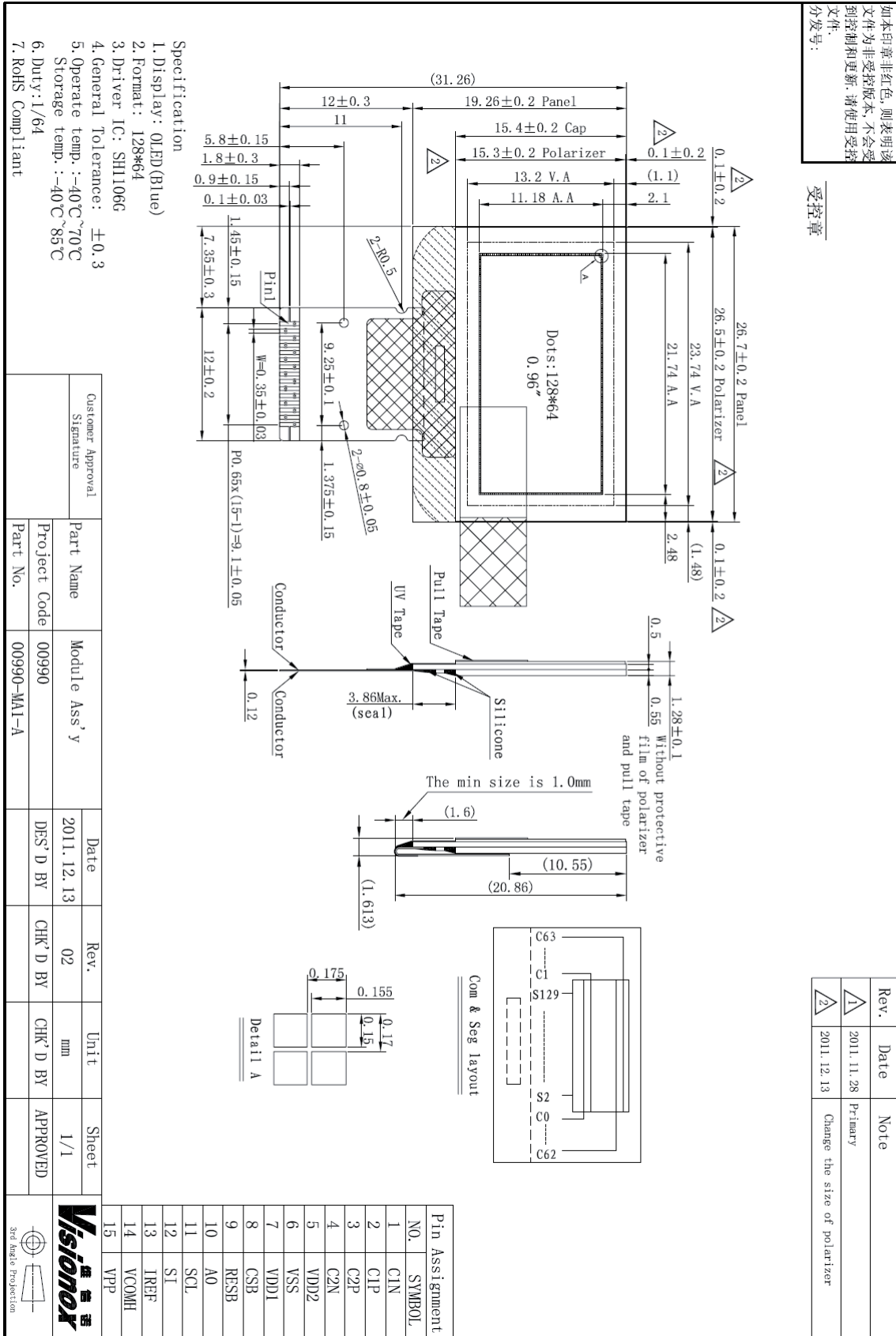

5 Module Interface

PIN NO.	PIN NAME	DESCRIPTION
1	C1N	Connect to charge pump capacitor.
2	C1P	These pins are not used and should be disconnected when VPP is supplied externally.
3	C2P	Connect to charge pump capacitor.
4	C2N	These pins are not used and should be disconnected when VPP is supplied externally.
5	VDD2	3.0 – 4.2V power supply pad for Power supply for charge pump circuit. This pin can be disconnected or connect to VDD1 when VPP is supplied externally
6	VSS	Ground.
7	VDD1	Power supply input: 1.65 - 3.5V
8	CSB	This pad is the chip select input. When CSB = “L”, then the chip select becomes active, and data/command I/O is enabled.
9	RESB	This is a reset signal input pad. When RESB is set to “L”, the settings are initialized. The reset operation is performed by the RESB signal level.
10	A0	This is the Data/Command control pad that determines whether the data bits are data or a command. A0 = “H”: the inputs at SI are treated as display data. A0 = “L”: the inputs at SI are transferred to the command registers.
11	SCL	serial clock input
12	SI	serial data input
13	IREF	This is a segment current reference pad. A resistor should be connected between this pad and VSS. Set the current at 10 μ A.
14	VCOMH	This is a pad for the voltage output high level for common signals. A capacitor should be connected between this pad and VSS.
15	VPP	OLED panel power supply. Generated by internal charge pump. Connect to capacitor. It could be supplied externally.

6 Function Block Diagram

6.1 Function Block Diagram

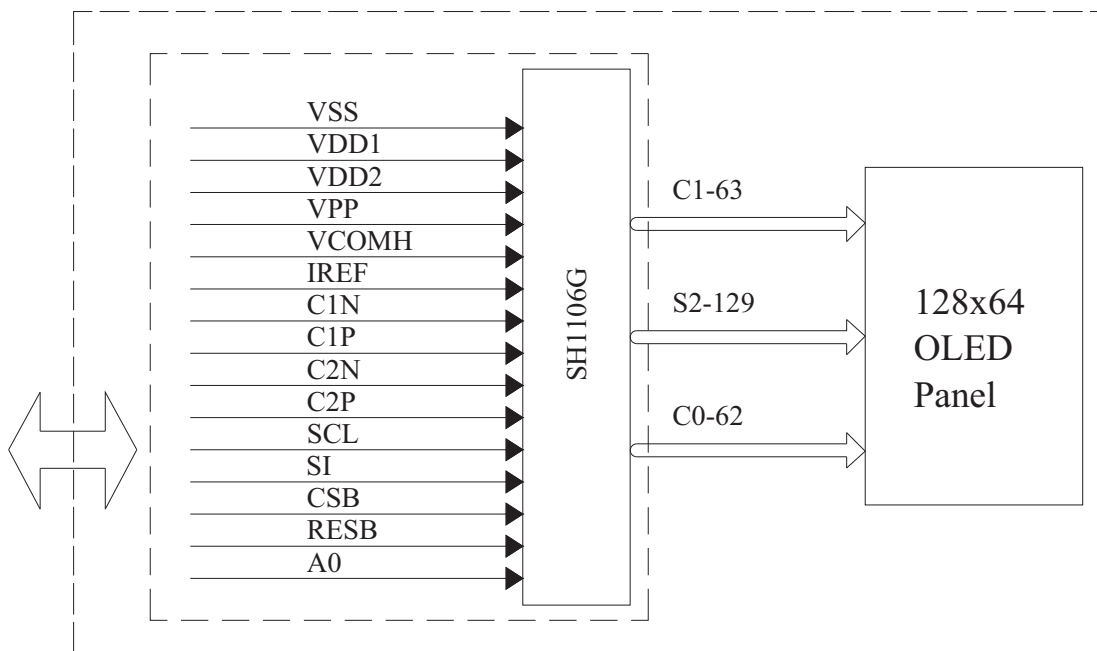

6.2 Panel Layout Diagram

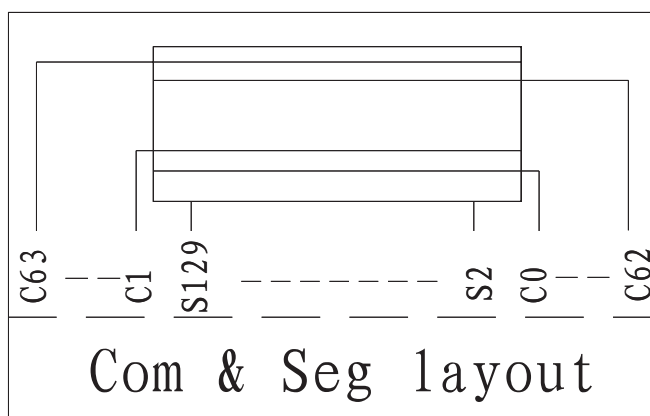

7 Absolute Maximum Ratings

ITEM	SYMBOL	MIN	MAX	UNIT	REMARK
Logic supply voltage	VDD1	-0.3	3.6	V	IC maximum rating
Charge Pump Regulator Supply Voltage	VDD2	-0.3	4.3	V	IC maximum rating
OLED Operating voltage	VPP	0	14.5	V	IC maximum rating
Operating Temp.	Top	-40	70	°C	-
Storage Temp	Tstg	-40	85	°C	-

Note (1): All of the voltages are on the basis of “VSS = 0V”.

Note (2): Permanent breakage of module may occur if the module is used beyond the maximum rating. The module can be normal operated under the conditions according to Section 8 “Electrical Characteristics”. Malfunctioning of the module may occur and the reliability of the module may deteriorate if the module is used beyond the conditions.

8 Electrical Characteristics

8.1 DC Electrical Characteristics

ITEM	SYMBOL	TEST CONDITION	MIN	TYP	MAX	UNIT
Logic Supply Voltage	VDD1	22±3°C, 55±15%R.H	1.65	2.8	3.5	V
OLED Driver Supply Voltage (Supply Externally)	VPP	22±3°C, 55±15%R.H	-	9	-	V
OLED Driver Supply Voltage (Generated by Internal DC/DC)	VPP	22±3°C, 55±15%R.H	-	8	-	V
Charge Pump Regulator Supply Voltage	VDD2	22±3°C, 55±15%R.H	3.0	3.7	4.2	V
High-level Input Voltage	V _{IHC}	-	0.8×VDD1	-	VDD1	V
Low-level Input Voltage	V _{ILC}	-	VSS	-	0.2×VDD1	V
High-level Output Voltage	V _{OHC}	-	0.8×VDD1	-	VDD1	V
Low-level Output Voltage	V _{OLC}	-	VSS	-	0.2×VDD1	V

Note : The VPP input must be kept in a stable value; ripple and noise are not allowed.

8.2 Electro-optical Characteristics

ITEM	SYMBOL	TEST CONDITION	MIN	TYP	MAX	UNIT
Normal Mode Brightness (With Polarizer)	L _{br}	All pixels ON(1)(2)	80	100	-	cd/m ²
Normal Mode Power Consumption	Pt	All pixels ON(1) (VPP generated by internal DC/DC)	-	124	148	mW
Normal Mode Power Consumption	Pt	All pixels ON(2) (VPP Supply Externally)	-	99	126	mW
Sleep mode current consumption in VDD1 & VDD2	I _{SP}	During sleep, TA = +25°C, VDD1 = 3V, VDD2 = 3V.	-	-	5	uA
Sleep mode current consumption in VPP		During sleep, TA = +25°C, VPP = 9V (External)	-	-	5	uA
C.I.E(Blue)	(x)	x,y(CIE1931)	0.12	0.16	0.20	-
	(y)		0.23	0.27	0.31	-
Dark Room Contrast	CR	-	≥2000:1	-	-	-
Response Time	-	-	-	10	-	μ s
View Angle	-	-	≥160	-	-	Degree

Note(1): Normal Mode test conditions are as follows:

- Driving voltage : VDD2:3.7V(VPP Generated by Internal DC/DC).
- Contrast setting : 0x50
- Frame rate : 105Hz
- Duty setting : 1/64

Note(2): Normal Mode test conditions are as follows:

- Driving voltage : 9.0V(VPP Supplied Externally).
- Contrast setting : 0x40
- Frame rate : 105Hz
- Duty setting : 1/64

8.3 AC Electrical Characteristics

(1) System buses Write characteristics 3 (For 4 wire SPI)

(VDD1 - VSS = 1.65V to 3.5V, TA = 25°C)

Symbol	Parameter	Min.	Typ.	Max.	Unit	Condition
t _{SCYC}	Serial clock cycle	500	-	-	ns	
t _{SAS}	Address setup time	300	-	-	ns	
t _{SAH}	Address hold time	300	-	-	ns	
t _{SDS}	Data setup time	200	-	-	ns	
t _{SDH}	Data hold time	200	-	-	ns	
t _{CSS}	\overline{CS} setup time	240	-	-	ns	
t _{CSH}	\overline{CS} hold time time	120	-	-	ns	
t _{SHW}	Serial clock H pulse width	200	-	-	ns	
t _{SLW}	Serial clock L pulse width	200	-	-	ns	
t _R	Rise time	-	-	30	ns	
t _F	Fall time	-	-	30	ns	

(VDD1 - VSS = 2.4V to 3.5V, TA = 25°C)

Symbol	Parameter	Min.	Typ.	Max.	Unit	Condition
t _{SCYC}	Serial clock cycle	250	-	-	ns	
t _{SAS}	Address setup time	150	-	-	ns	
t _{SAH}	Address hold time	150	-	-	ns	
t _{SDS}	Data setup time	100	-	-	ns	
t _{SDH}	Data hold time	100	-	-	ns	
t _{CSS}	\overline{CS} setup time	120	-	-	ns	
t _{CSH}	\overline{CS} hold time time	60	-	-	ns	
t _{SHW}	Serial clock H pulse	100	-	-	ns	
t _{SLW}	Serial clock L pulse	100	-	-	ns	
t _R	Rise time	-	-	15	ns	
t _F	Fall time	-	-	15	ns	

4-wire Serial interface characteristics

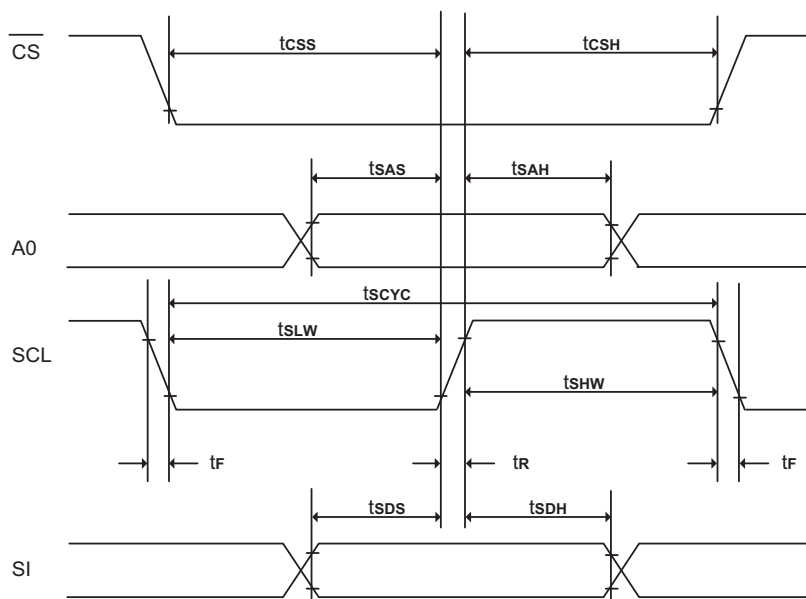

9 Functional Specification and Application Circuit

9.1 Power ON and Power OFF Sequence

Power ON Sequence:

1. Power ON VDD1.
2. After VDD1 become stable, set RES pin LOW (logic low) for at least 5us (t_1) and then HIGH (logic high).
3. After set RESB pin LOW (logic low), wait for at least 5us (t_2). Then Power ON VPP. (1)
4. After VPP become stable, send command AFh for display ON. SEG/COM will be ON after 100ms(t_{AF}).

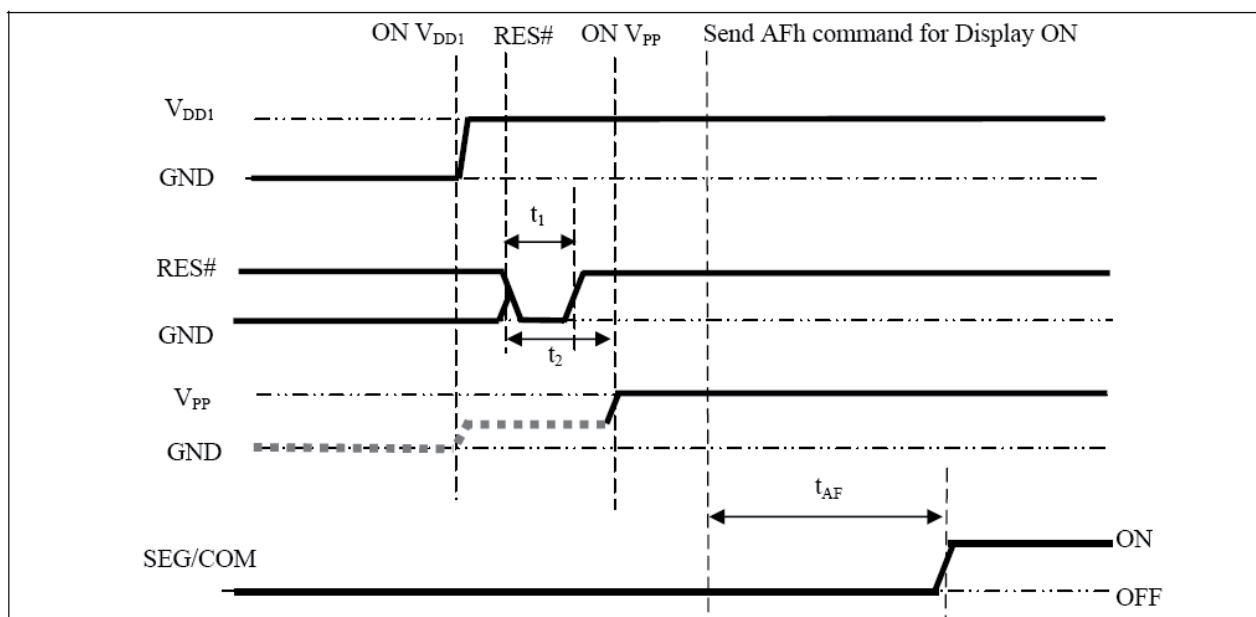

Power OFF Sequence:

1. Send command AEh for display OFF.
2. Power OFF VPP.(1), (2)
3. Wait for t_{OFF} . Power OFF VDD1. (where Minimum t_{OFF} =0ms, Typical t_{OFF} =100ms)

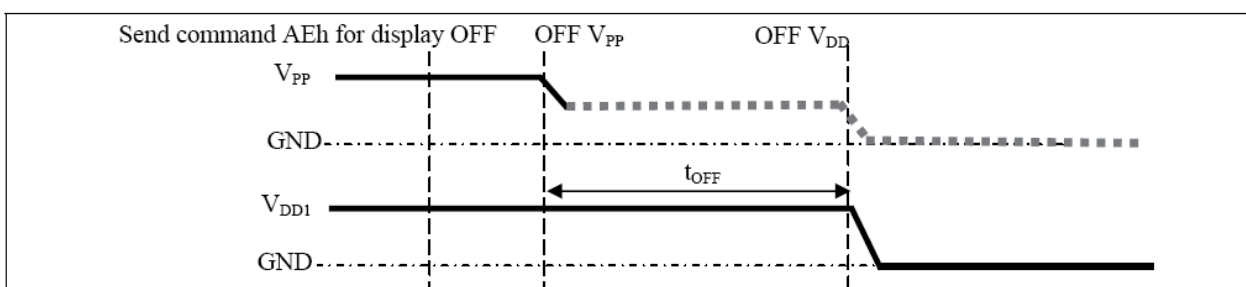

Note:

- (1) Since an ESD protection circuit is connected between VDD1 and VPP, VPP becomes lower than VDD1 whenever VDD1 is ON and VPP is OFF as shown in the dotted line of VPP in above figures.
- (2) VPP should be kept float (disable) when it is OFF.

9.2 Application Circuit

9.2.1 The configuration for VPP Generated by Internal DC/DC Circuit is shown in the following diagram:

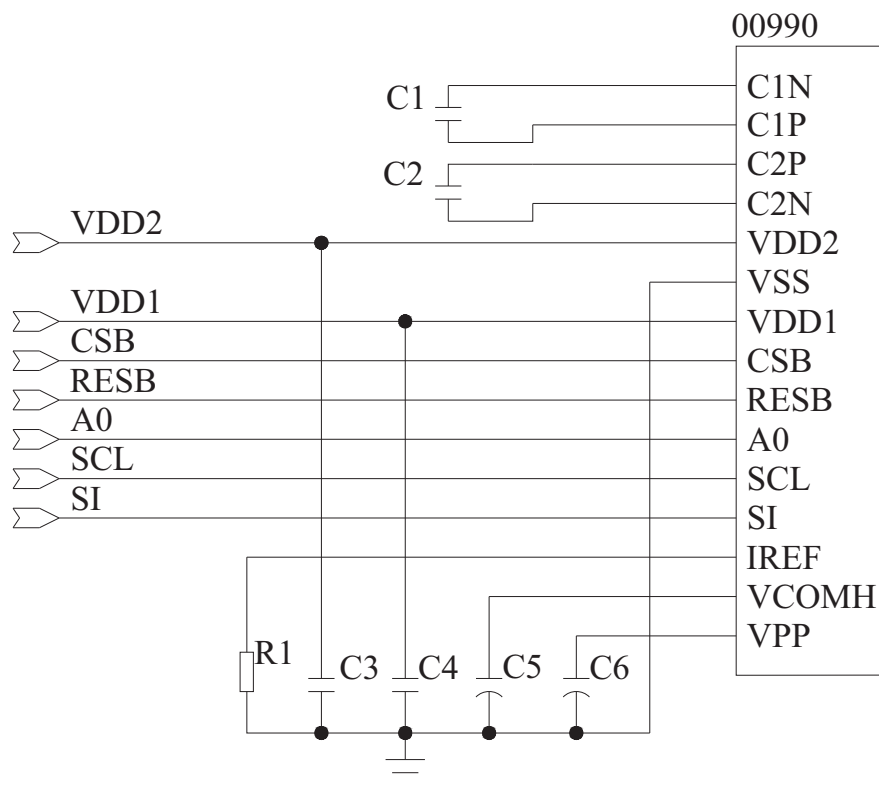

Pin connected to MCU interface: SCL,SI,CSB,RESB,A0.

Under Internal DC/DC Mode, the Charge Pump Setting(ADh) must be set as follow:

ADh: Charge Pump Setting

8Bh: Enable Charge Pump

Recommended components

C1, C2 : 1uF-0603-X7R±10%.RoHS

C3, C5, C6 : 4.7μF/16V.ROHS (Tantalum Capacitors)

C4: 0.1uF-0603-X7R±10%.RoHS

R1: 0603 1/10W +/-5% 390Kohm.RoHS

9.2.2 The configuration for 4-wire SPI interface mode, external VPP is shown in the following diagram

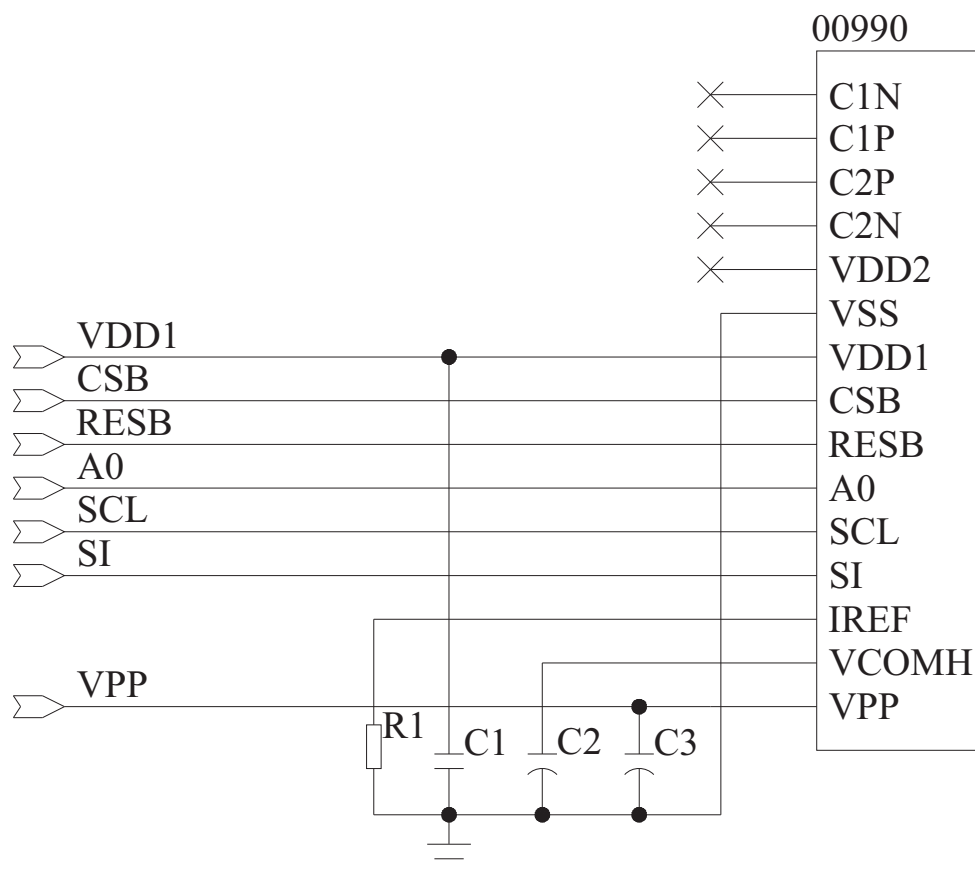

Pin connected to MCU interface: SCL,SI,CSB,RESB,A0.

Under external VPP Mode, the Charge Pump Setting(ADh) must be set as follow:

ADh: Charge Pump Setting

8Ah: Disable Charge Pump

Recommended components

C1: 0.1uF-0603-X7R±10%.RoHS

C2, C3 : 4.7μF/16V.ROHS (Tantalum Capacitors)

R1: 0603 1/10W +/-5% 390Kohm.RoHS

9.3 External DC-DC application circuit

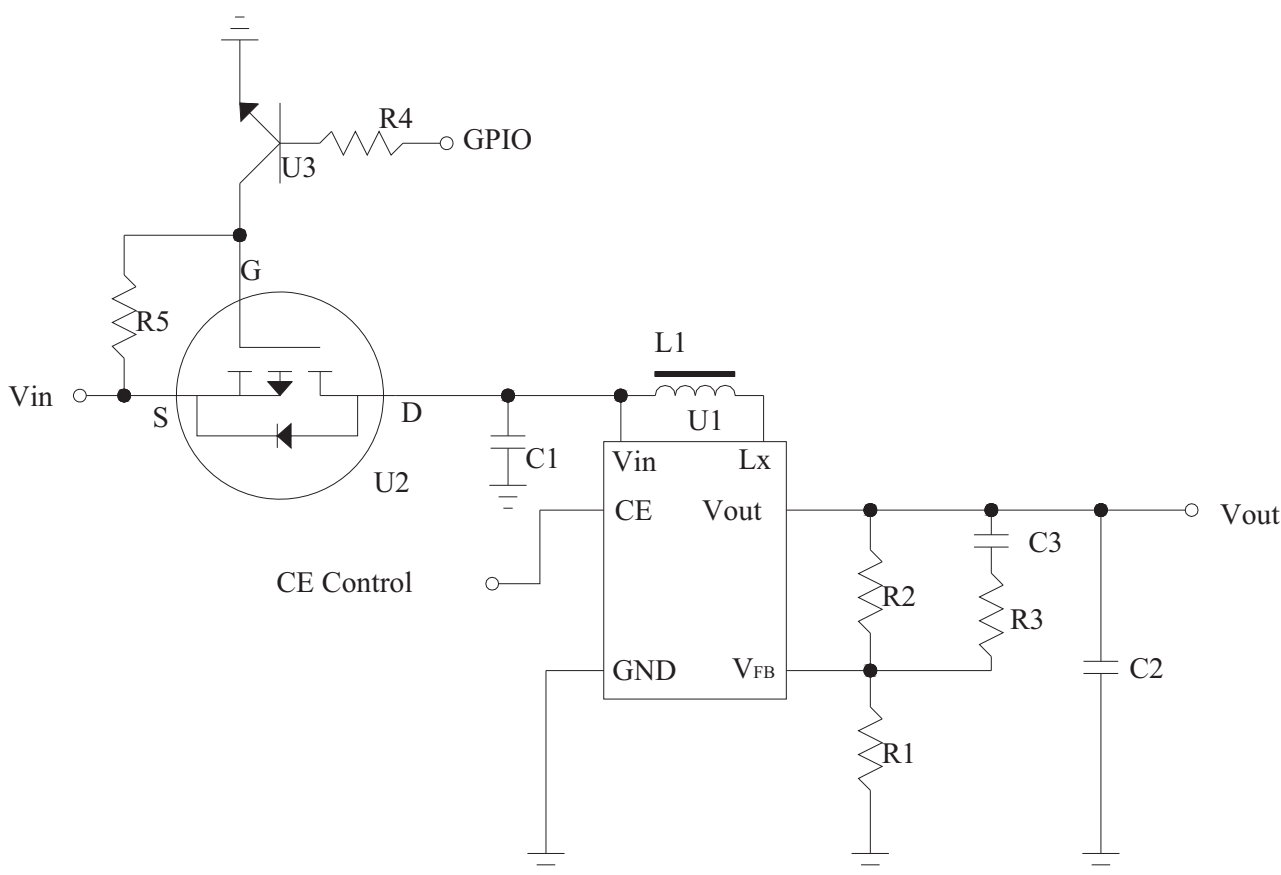

Recommend component

The C1	: 1 uF-0603-X7R±10%.ROHS
The C2	: 1 uF-0603-X7R±10%.ROHS
The C3	: 220pF-0603-X7R±10%.ROHS
The R1	: 0603 1/10W +/-5% 10Kohm.ROHS
The R2	: 0603 1/10W +/-5% 80Kohm.ROHS
The R3	: 0603 1/10W +/-5% 2Kohm.ROHS
The R4	: 0603 1/10W +/-5% 1Kohm.ROHS
The R5	: 0603 1/10W +/-5% 10Kohm.ROHS
The L1	: 22uH
The U1	: R1200
The U2	: FDN338P
The U3	: 8050





9.4 Display Control Instruction

Refer to SH1106G IC Specification.

9.5 Recommended Software Initialization

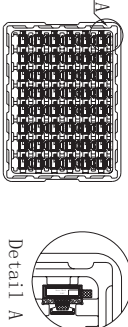
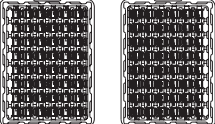
```
void Init_IC()
{
    Write_Command(0xAE);    //Set Display Off
    Write_Command(0xD5);    //display divide ratio/osc. freq. mode
    Write_Command(0x80);    //
    Write_Command(0xA8);    //multiplex ration mode:63
    Write_Command(0x3F);
    Write_Command(0xD3);    //Set Display Offset
    Write_Command(0x00);
    Write_Command(0x40);    //Set Display Start Line
    Write_Command(0xAD);    //DC-DC Control Mode Set
    Write_Command(0x8B);    //DC-DC ON/OFF Mode Set
    Write_Command(0x32);    //Set Pump voltage value
    Write_Command(0xA1);    //Segment Remap
    Write_Command(0xC8);    //Sst COM Output Scan Direction
    Write_Command(0xDA);    //common pads hardware: alternative
    Write_Command(0x12);
    Write_Command(0x81);    //contrast control
    Write_Command(0x50);
    Write_Command(0xD9);    //set pre-charge period
    Write_Command(0x1F);
    Write_Command(0xDB);    //VCOM deselect level mode
    Write_Command(0x40);    //
    Write_Command(0xA4);    //Set Entire Display On/Off
    Write_Command(0xA6);    //Set Normal Display
    Write_Command(0xAF);    //Set Display On
}
```

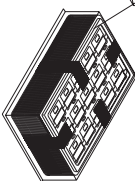
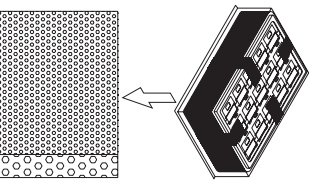
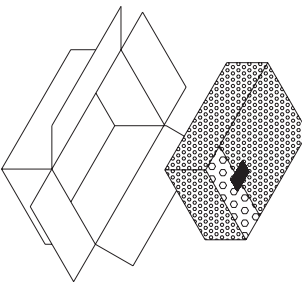
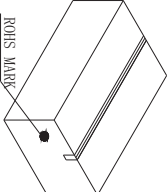
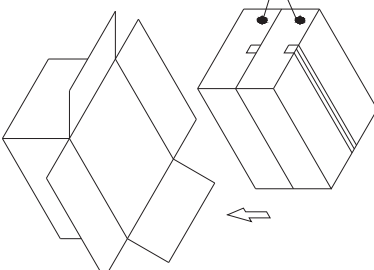
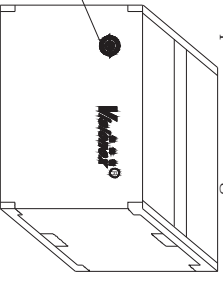
10 Package Specification

Controlled Seal		Packing Process (1)~(9)		
<p>(1) Tray Type:00693-MT6-A</p> 	<p>(2)</p>  <p>TRAY</p>	<p>(3) order ①、② ① ② fix trays with tape 1056 pcs of 1 small carton 1 tray contain 48 pcs 22 contained trays, 1 empty tray</p> 	<p>(4) Use vacuum bag to package the tray and add 5 bags of desiccant into the vacuum bag *5</p> 	
<p>(5) After tray be packaged, wrap the package in a bubble bag and seal with scotch tape.</p> 	<p>(6)</p> 	<p>(7)</p> <p>small carton package L390*W290*L120 mm</p> 	<p>(8)</p> <p>2 small cartons in 1 big carton</p> 	
<p>(9) 44 contained trays, 2 empty trays, Package quantity products: 2112 pcs of 1 big carton</p>  <p>Package finished L410*W310*L272 mm</p>	<p>NOTE:1、The inner carton and master carton must be sealed with adhesive tape. 2、Fill up the gap with tray. 3、If the customer has special needs with the RoHS making, the inner carton and master carton need adhesive new RoHS marking at .</p>			

11 Reliability

11.1 Reliability Test

NO.	ITEM	CONDITION	QUANTITY
1	High Temperature (Non-operation)	85°C,240hrs	4
2	Low Temperature (Non-operation)	-40°C,240hrs	4
3	High Temperature (Operation)	70°C,240hrs	4
4	Low Temperature (Operation)	-40°C,240hrs	4
5	High Temperature / High Humidity (Operation)	60°C,90%RH,240hrs	4
6	Thermal shock (Non-operation)	-40°C~85°C(-40°C/30min;transit/3min;85°C/30min;transit/3min) 1cycle: 66min,30cycles	4
7	Vibration	Frequency: 5~50Hz,0.5G Scan rate: 1 oct/min Time: 2 hrs/axis Test axis: X,Y, Z	1 Carton
8	Drop	Height: 100 cm Sequence: 1 angle, 3 edges and 6 faces	1 Carton

Test and measurement conditions

- All measurements shall not be started until the specimens attain to temperature stability, the stable time is at least 15 minutes.
- The degradation of polarizer is ignored for item 5.
- The tolerance of temperature is $\pm 3^{\circ}\text{C}$, and the tolerance of relative humidity is $\pm 5\%$.

Evaluation criteria

- The function test is OK.
- No observable defects.
- Luminance: $\geq 50\%$ of initial value.
- Current consumption: within $\pm 50\%$ of initial value.

11.2 Lifetime

End of lifetime is specified as 50% of initial brightness and the test pattern at operating condition is 50% alternating checkerboard.

ITEM	MIN	MAX	UNIT	CONDITION
Operation Life Time	10,000	-	hrs	100cd/m ² , 50% alternating checkerboard, 22 \pm 3°C, 55 \pm 15% RH

11.3 Failure Check Standard

After the completion of the described reliability test, the samples were left at room temperature for 2 hrs prior to conducting the failure test at 22 \pm 3°C; 55 \pm 15% RH.

12 Illustration of OLED Product Name

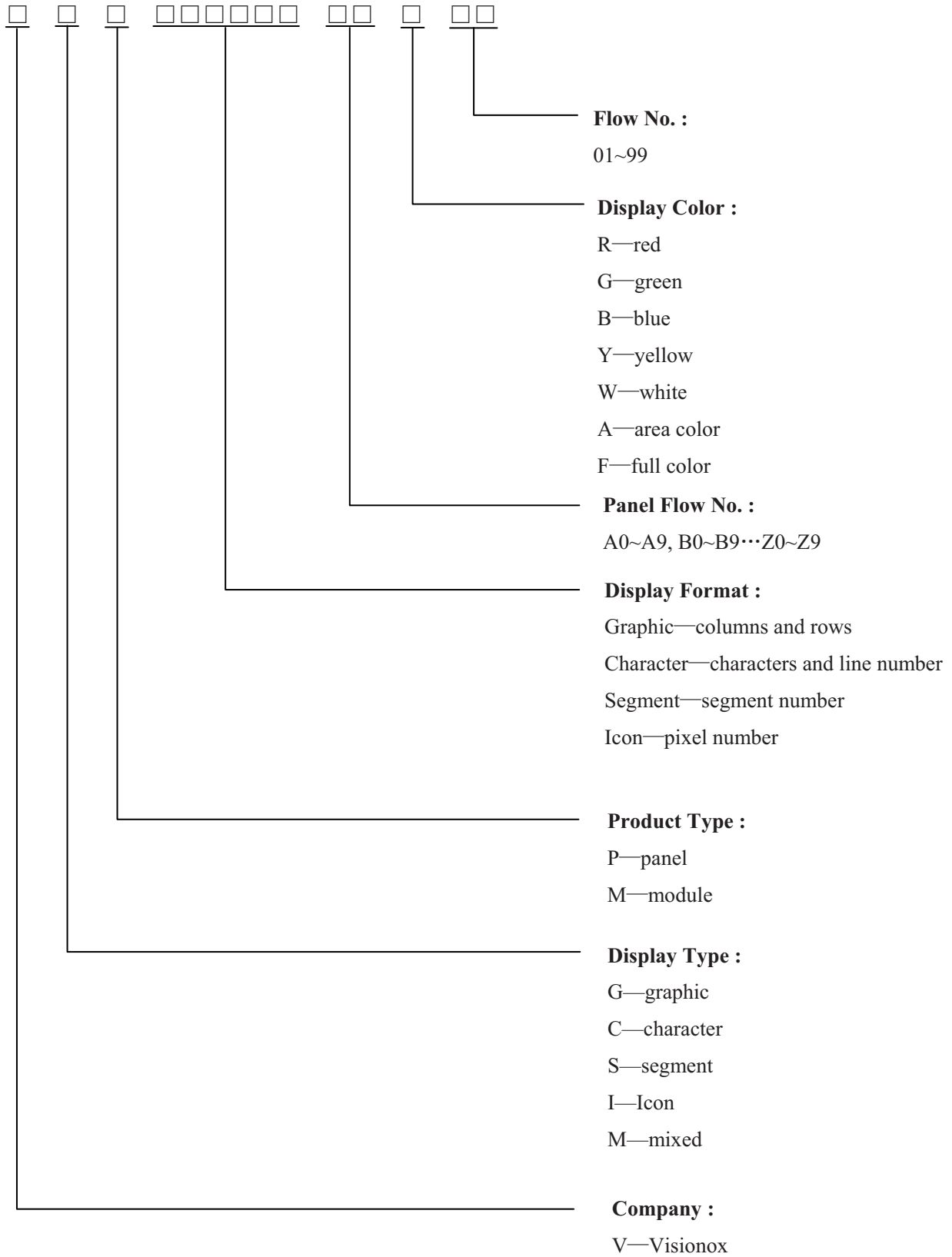

13 Outgoing Quality Control Specifications

13.1 Sampling Method

- (1) GB/T 2828.1-2003/ISO2859-1: 1999, inspection level II, normal inspection, single sample inspection
- (2) AQL: Major 0.65; Minor 1.0

13.2 Inspection Conditions

The environmental conditions for test and measurement are performed as follows.

Temperature: $22 \pm 3^{\circ}\text{C}$

Humidity: $55 \pm 15\% \text{R.H}$

Fluorescent Lamp: 30W

Distance between the Panel & Lamp: $\geq 50\text{cm}$

Distance between the Panel & Eyes: $\geq 30\text{cm}$

Viewing angle from the vertical in each direction: $\leq 45^{\circ}$

(See the sketch below)

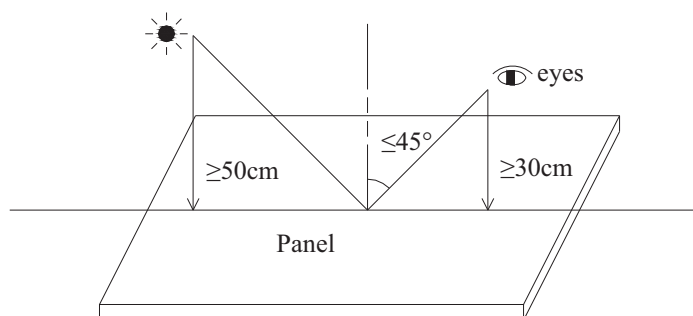

13.3 Quality Assurance Zones

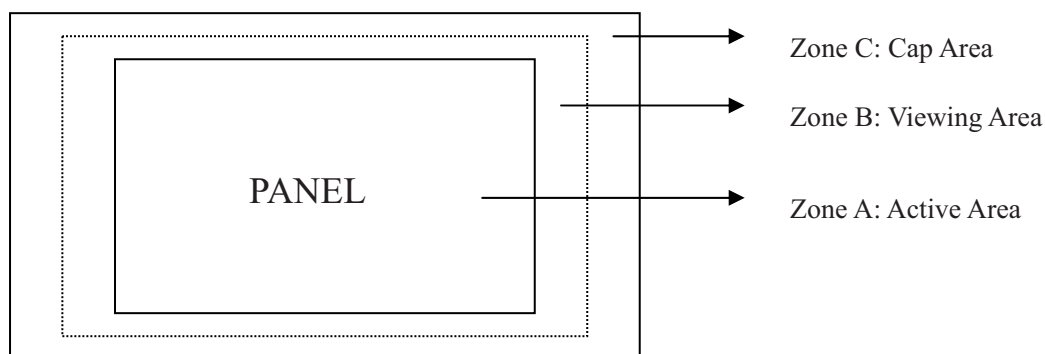

13.4 Inspection Standard

Definition of Φ &L&W (Unit: mm)

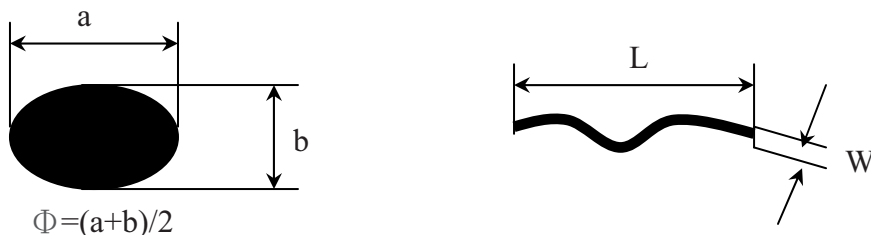

I . Appearance Defects

NO.	ITEM	CRITERIA	CLASSIFICATION																
1	Polarizer Black or White spot, Dirty spot, Foreign matter, Dent on the polarizer	<table border="1"> <thead> <tr> <th rowspan="2">Average Diameter (mm)</th> <th colspan="2">Acceptable Number</th> </tr> <tr> <th>Zone A,B</th> <th>Zone C</th> </tr> </thead> <tbody> <tr> <td>$\Phi \leq 0.15$</td> <td>Ignore</td> <td rowspan="3">Ignore</td> </tr> <tr> <td>$0.15 < \Phi \leq 0.30$</td> <td>3</td> </tr> <tr> <td>$\Phi > 0.30$</td> <td>0</td> </tr> </tbody> </table>	Average Diameter (mm)	Acceptable Number		Zone A,B	Zone C	$\Phi \leq 0.15$	Ignore	Ignore	$0.15 < \Phi \leq 0.30$	3	$\Phi > 0.30$	0	Minor				
Average Diameter (mm)	Acceptable Number																		
	Zone A,B	Zone C																	
$\Phi \leq 0.15$	Ignore	Ignore																	
$0.15 < \Phi \leq 0.30$	3																		
$\Phi > 0.30$	0																		
2	Scratch/line on the glass/Polarizer	<table border="1"> <thead> <tr> <th rowspan="2">Width (mm)</th> <th rowspan="2">Length (mm)</th> <th colspan="2">Acceptable Number</th> </tr> <tr> <th>Zone A,B</th> <th>Zone C</th> </tr> </thead> <tbody> <tr> <td>$W \leq 0.03$</td> <td>---</td> <td>Ignore</td> <td rowspan="3">Ignore</td> </tr> <tr> <td>$0.03 < W \leq 0.08$</td> <td>$L \leq 5.0$</td> <td>3</td> </tr> <tr> <td>$W > 0.08$</td> <td>---</td> <td>0</td> </tr> </tbody> </table>	Width (mm)	Length (mm)	Acceptable Number		Zone A,B	Zone C	$W \leq 0.03$	---	Ignore	Ignore	$0.03 < W \leq 0.08$	$L \leq 5.0$	3	$W > 0.08$	---	0	Minor
Width (mm)	Length (mm)	Acceptable Number																	
		Zone A,B	Zone C																
$W \leq 0.03$	---	Ignore	Ignore																
$0.03 < W \leq 0.08$	$L \leq 5.0$	3																	
$W > 0.08$	---	0																	
3	Polarizer Bubble	<table border="1"> <thead> <tr> <th rowspan="2">Average Diameter (mm)</th> <th colspan="2">Acceptable Number</th> </tr> <tr> <th>Zone A,B</th> <th>Zone C</th> </tr> </thead> <tbody> <tr> <td>$\Phi > 0.5$</td> <td>0</td> <td rowspan="3">Ignore</td> </tr> <tr> <td>$0.2 < \Phi \leq 0.5$</td> <td>3</td> </tr> <tr> <td>$\Phi \leq 0.2$</td> <td>Ignore</td> </tr> </tbody> </table>	Average Diameter (mm)	Acceptable Number		Zone A,B	Zone C	$\Phi > 0.5$	0	Ignore	$0.2 < \Phi \leq 0.5$	3	$\Phi \leq 0.2$	Ignore	Minor				
Average Diameter (mm)	Acceptable Number																		
	Zone A,B	Zone C																	
$\Phi > 0.5$	0	Ignore																	
$0.2 < \Phi \leq 0.5$	3																		
$\Phi \leq 0.2$	Ignore																		
4	Any Dirt & Scratch on Polarizer's Protective Film	Ignore for not affect the polarizer.	Acceptable																
5	Any Dirt on Cap Glass	<table border="1"> <thead> <tr> <th>Average Diameter (mm)</th> <th>Acceptable Number</th> </tr> </thead> <tbody> <tr> <td>$\Phi \leq 0.5$</td> <td>Ignore</td> </tr> <tr> <td>$0.5 < \Phi \leq 1.0$</td> <td>3</td> </tr> <tr> <td>$\Phi > 1.0$</td> <td>0</td> </tr> </tbody> </table>	Average Diameter (mm)	Acceptable Number	$\Phi \leq 0.5$	Ignore	$0.5 < \Phi \leq 1.0$	3	$\Phi > 1.0$	0	Minor								
Average Diameter (mm)	Acceptable Number																		
$\Phi \leq 0.5$	Ignore																		
$0.5 < \Phi \leq 1.0$	3																		
$\Phi > 1.0$	0																		

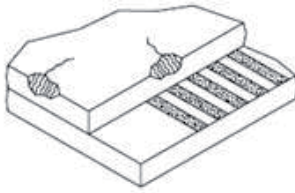
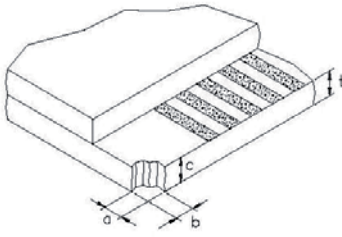
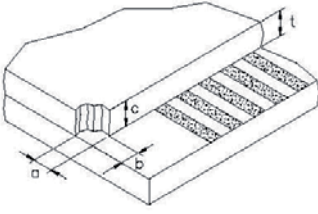
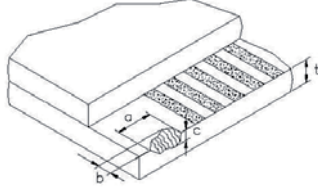
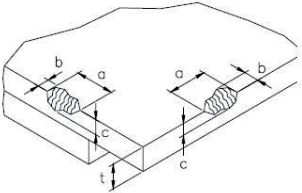
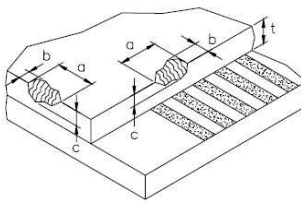
6	Glass Crack	 Propagation crack is not acceptable.	Major
7	Corner Chip	 $t = \text{Glass thickness}$ Accept $a \leq 2.0\text{mm}$ or $b \leq 2.0\text{mm}$, $c \leq t$	Minor
8	Corner Chip on Cap Glass	 $t = \text{Glass thickness}$ Accept $a \leq 1.5\text{mm}$ or $b \leq 1.5\text{mm}$, $c \leq t$	Minor
9	Chip on Contact Pad	 $t = \text{Glass thickness}$ Accept $a \leq 3.0\text{mm}$ or $b \leq 0.8\text{mm}$, $c \leq t$ (on the contact pin) $a \leq 3.0\text{mm}$ or $b \leq 1.5\text{mm}$, $c \leq t$ (outside of the contact pin)	Minor
10	Chip on Face of Display	 $t = \text{Glass thickness}$ Accept $a \leq 1.5\text{mm}$ or $b \leq 1.5\text{mm}$, $c \leq t$	Minor
11	Chip on Cap Glass	 $t = \text{Glass thickness}$ Accept $a \leq 3.0\text{mm}$ or $b \leq 3.0\text{mm}$, $c \leq t/2$ $a \leq 1.5\text{mm}$ or $b \leq 1.5\text{mm}$, $t/2 \leq c \leq t$	Minor
12	Stain on Surface	Stain removable by soft cloth or air blow is acceptable.	Minor
13	TCP/FPC Damage	(1) Crack, deep scratch, deep hole and deep pressure mark on the TCP/FPC are not acceptable. (2) Terminal lead twisted or broken is not allowable. (3) Copper exposed is not allowed by naked eye inspection.	Minor
14	Dimension Unconformity	Checking by mechanical drawing.	Major

II. Displaying Defects

NO.	ITEM	CRITERIA	CLASSIFICATION													
1	Black/White spot Dirty spot Foreign matter	<table border="1"> <thead> <tr> <th rowspan="2">Average Diameter (mm)</th> <th colspan="2">Pieces Permitted</th> </tr> <tr> <th>Zone A,B</th> <th>Zone C</th> </tr> </thead> <tbody> <tr> <td>$\Phi \leq 0.10$</td> <td colspan="2">Ignore</td> </tr> <tr> <td>$0.10 < \Phi \leq 0.20$</td> <td>3</td> <td rowspan="2">Ignore</td> </tr> <tr> <td>$\Phi > 0.20$</td> <td>0</td> </tr> </tbody> </table>	Average Diameter (mm)	Pieces Permitted		Zone A,B	Zone C	$\Phi \leq 0.10$	Ignore		$0.10 < \Phi \leq 0.20$	3	Ignore	$\Phi > 0.20$	0	Minor
		Average Diameter (mm)		Pieces Permitted												
			Zone A,B	Zone C												
		$\Phi \leq 0.10$	Ignore													
$0.10 < \Phi \leq 0.20$	3	Ignore														
$\Phi > 0.20$	0															
2	No Display	Not allowable.	Major													
3	Irregular Display	Not allowable.	Major													
4	Missing Line (row or column)	Not allowable.	Major													
5	Short	Not allowable.	Major													
6	Flicker	Not allowable.	Major													
7	Abnormal Color	Refer to the SPEC.	Major													
8	Luminance NG	Refer to the SPEC.	Major													
9	Over Current	Refer to the SPEC.	Major													

14 Precautions for operation and Storage

14.1 Precautions for Operation

- (1) Since OLED panel is made of glass, do not apply any mechanical shock or impact or excessive force to it when installing the OLED module. Any strong mechanical impact due to falling dropping etc. may cause damage (breakage or cracking).
- (2) The polarizer on the OLED surface is made of soft material and is easily scratched. Please take most care when handing. When the surface of the polarizer of OLED Module is contaminated, please wipe it off gently by using moisten soft cloth with isopropyl alcohol, do not use water, ketone or aromatics. If there is saliva or water on the OLED surface, please wipe it off immediately.
- (3) When handling OLED module, please be sure that the body and the tools are properly grounded. And do not touch I/O pins with bare hands or contaminate I/O pins, it will cause disconnection or defective insulation of terminals.
- (4) Do not attempt to disassemble or process the OLED module.
- (5) OLED module should be used under recommended operating conditions shown in the specification. Since the higher voltage leads to the shorter lifetime, be sure to use the specified operating voltage.
- (6) Foggy dew, moisture condensation or water droplets deposited on surface and contact terminals will cause polarizer stain or damage, the deteriorated display quality and electrochemical reaction then leads to shorter life time and permanent damage to the module probably. Please pay attention to the environmental temperature and humidity.
- (7) An afterimage is created by the difference in brightness between unused dot and the fixed dot, according to the decrease of brightness of the emitting time. Therefore, to avoid having an afterimage, the full set should be thoroughly used instead of using a fixed dot. When the fixed dot emits, an afterimage can be created.
- (8) Flicker could be come out at full on display. And it disappears when frame frequency increase, but brightness decreases too.

14.2 Soldering

- (1) Soldering should be performed only on the I/O terminals.
- (2) Use soldering irons with proper grounding and no leakage.
- (3) Iron: no higher than 300°C and 3~4 sec during soldering.

14.3 Precautions for Storage

- (1) Please store OLED module in a dark place. Avoid exposure to sunlight, the light of fluorescent lamp or any ultraviolet ray.
- (2) Keep the environment temperature between 10°C and 35°C and the relative humidity less than 60%. Avoid high temperature and high humidity.
- (3) Keep the OLED modules stored in the container when shipped from supplier before using them is recommended.
- (4) Do not leave any article on the OLED module surface for an extended period of time.

14.4 Warranty period

Visionox warrants for a period of 12 months from the shipping date when stored or used under normal condition.